

**SPECIFICATION 700.
KERBS AND SIDEWALKS.**

1. SCOPE OF THE WORKS :- The Scope of The Works includes the construction of concrete kerbs, concrete sidewalks, and concrete driveways, together with associated ancillary works. The ancillary works include working around existing electricity poles, stay wires and utility access covers. Kerb and sidewalks shall be constructed as shown on NRA Drawing titled "Typical Kerb and Sidewalk Details". The scope of the work also includes the safe control of pedestrians and traffic around the work site, for the removal of all damaged or surplus material, and for leaving the work site in a clean and orderly condition.
2. BASE WORKS :- NRA proposes to complete the adjacent roadworks, except for the 2ins thick Hot Mix Asphalt surface, before the concrete works are commenced. The roadbase would however be given a temporary spray and chip surface for weather protection. The top of kerb will therefore be approximately 8ins above the spray and chip surface. Where appropriate, NRA will remove the existing sidewalk. Unless otherwise provided for in The Contract, NRA will place the granular base from the proposed kerbline to the back of the proposed sidewalk or driveway, to an elevation 4ins below the finished sidewalk, or 6ins below the finished driveway to an accuracy of $\pm 0.0-1/12$ ins. The Contractor will be responsible for the excavation of the kerb foundation, the disposal of the spoil, and the replacement of any excess excavation with concrete.
3. HARD EXCAVATION :- It is assumed that excavation of the kerb foundation will be by a standard rubber tyred backhoe in good working order, including the teeth on the bucket. If the excavation proves to be too hard for such a machine, NRA will either provide the plant and labour to remove the obstruction, or may authorize the contractor to provide a reduced thickness of foundation to the kerb.
4. PRECAST CONCRETE KERBS :- Precast concrete (PCC) kerbs must be obtained from one source to ensure a uniformity of shape, size, finish, and colour. The concrete used for PCC kerbs should have a minimum 28 day strength of 4000 psi, and shall be compacted in the molds mechanically. The nominal size of the units shall be 10ins x 5ins x 36ins with a 5ins x 1ins half batter. The height, width, and length should not deviate by more than 1/8th ins from the given nominal size and the units shall not be twisted or out of square. The front face, batter face, and top face of the units shall not vary by more than 1/16th ins from the true straight or radius line in the 56ins length of the unit. The surface of the units must be free from air holes, cracks, and blemishes. The quality of the PCC kerbs shall be to the satisfaction of the Project Manager (PM). PCC kerbs shall be placed on cured foundation concrete using 12ins of 3:1 sand cement mortar. Kerb units may either be tightly butted against one another, or separated by a 1/2ins joint filled with 3:1 sand cement mortar. Other methods of working may be agreed with the PM. Kerbs without an adjacent sidewalk, shall be provided with a supporting haunch as shown on The Drawings.
5. SLIP FORMED KERBS :- The NRA will accept a slip formed kerb and gutter (Florida DOT Type F) in place of PCC kerbs, provided that any proposed contract allows for that alternative, and that the alternative is agreed before the contract is signed. Slip formed kerbs and gutters shall be 4000psi concrete at 28 days. Errors in line and elevation, and surface blemishes, shall be corrected immediately after the concrete leaves the mold while the uncured concrete is still plastic. The kerb and gutter shall have a brushed finish with the brush strokes perpendicular to the face of the kerb. Slip formed kerbs shall have a Type "C" sawn joint every 12ft, to be cut immediately after the concrete has gelled. Type F kerbs do not need a supporting haunch in the absence of a sidewalk.
6. UNDERGROUND UTILITIES :- Prior to kerb excavation, NRA will point out the location of known underground services. The contractor will from them on be responsible for their protection and repair. NRA will be responsible for the repair of any previously unknown services that impinge on the excavation profile shown on the drawings.
7. PLAIN AND REINFORCED CONCRETE :- Plain and reinforced concrete shall be in accordance with the Cayman Islands PWD standard concrete specification. Spraying with a reflective resin coating will be an acceptable alternative to curing the concrete with water. Spacer blocks for the 6 x 6 x #10 Mesh to the driveway concrete, shall be equal in strength to the parent concrete, and the minimum spacing shall be 30ins c/c. Pieces of broken hollow concrete blocks shall not be acceptable as spacer blocks. All cast in situ concrete shall be compacted with a mechanical vibrator. Unless otherwise shown on The Drawings, sidewalks and driveways will have a brushed finish with the brush strokes perpendicular to the kerb face, and with a 3ins troweled margin at the back and front. Contraction joints Type C should be cut into the brushed surface with a mechanical concrete saw, as soon as the concrete has gelled, and should not have troweled margins. Joints in sidewalks and driveways must be in line with the joints in the adjacent kerb.
8. SETTING OUT :- NRA will provide setting out in plan by means of a pin placed on the line of the face of the kerb, at 25ft centres, and at the beginning and end of curves, and at changes in gradient. The finished elevation of the top of the kerb will be marked on the pin by the top of a piece of adhesive tape. The given elevations will not take into account the driveways and handdrapped ramps which are to be 11/2ins above adjacent finished road level (FRL). Alternative methods of setting out may be agreed with the PM. No part of any sidewalk should have a gradient of more than 1:12. Sidewalks shall slope towards the road at 1ins in 6ft unless otherwise specified. Driveways shall slope to suit the site conditions, but shall have a slope of not less than 1ins in 6ft, nor greater than 1:12.
9. ACCURACY :- PCC kerbs, slipformed kerbs, sidewalks, and driveways shall be to the satisfaction of the PM. Deviations of more than 0.2ft from the line and elevation shown on The Drawings, or from the setting out provided by the NRA, or of more than 0.2ft deviation when tested with a 10ft straight edge, shall be a cause for rejection by the PM.

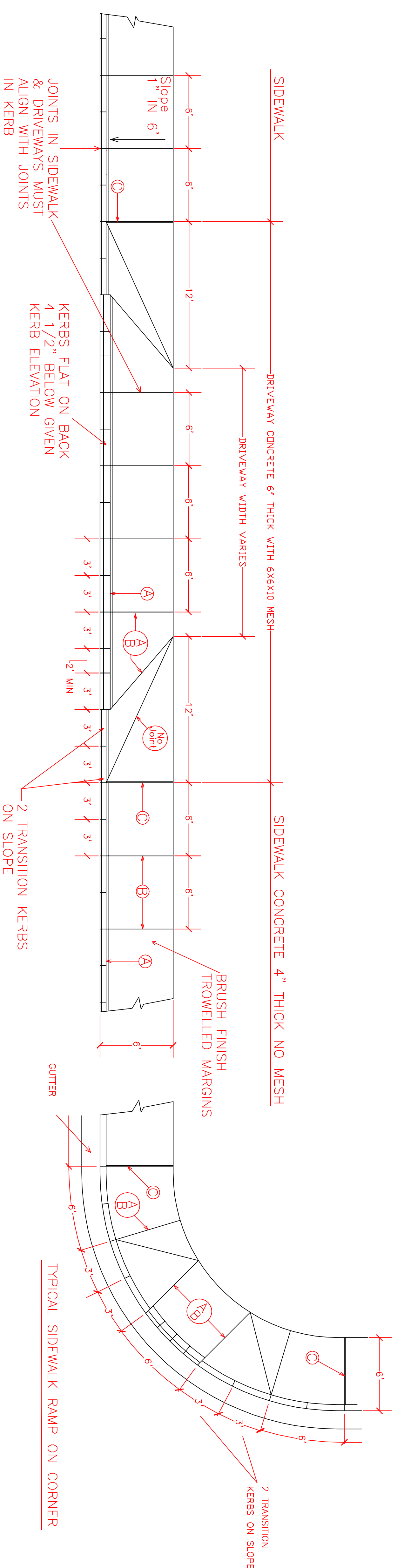

TYPE 'C' JOINTS TO BE USED AT EACH SIDE OF DRIVEWAYS, PEDESTRIAN RAMPS, AT INTERVALS NOT GREATER THAN 96ft ALONG SIDEWALK, AND AT THE TANGENT POINTS OF SECTIONS OF CURVED IN PLAN.

PLAN VIEW OF DRIVEWAY AND SIDEWALK
SCALE : 1" = 50"

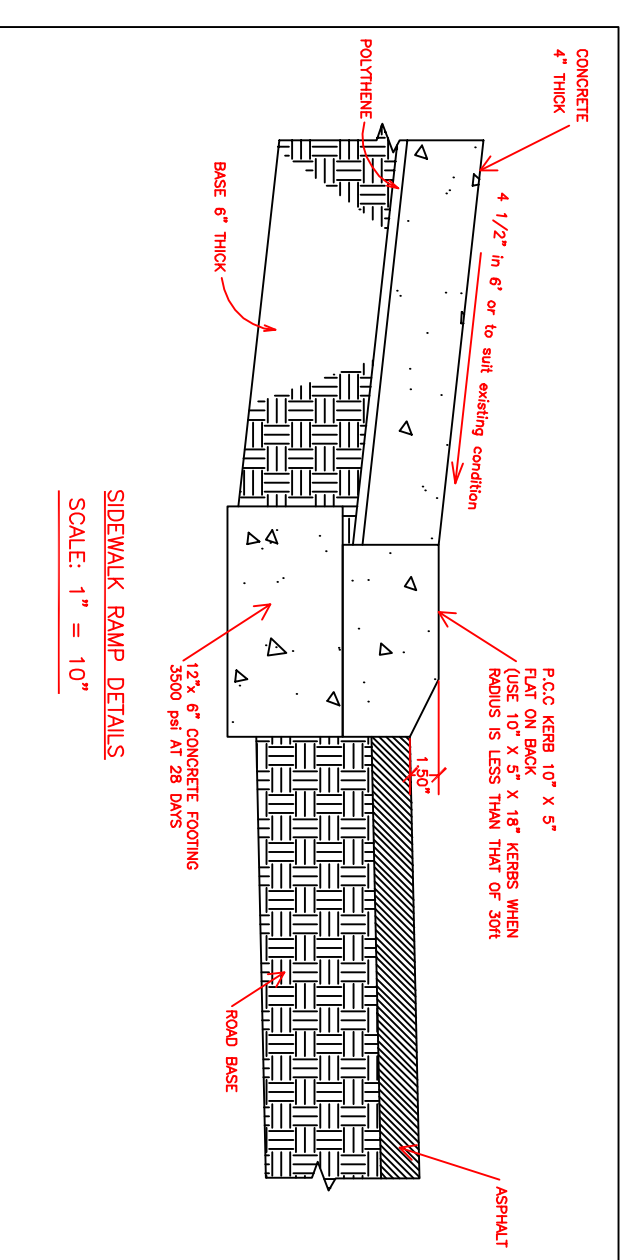

SIDEWALK RAMP DETAILS
SCALE : 1" = 10"

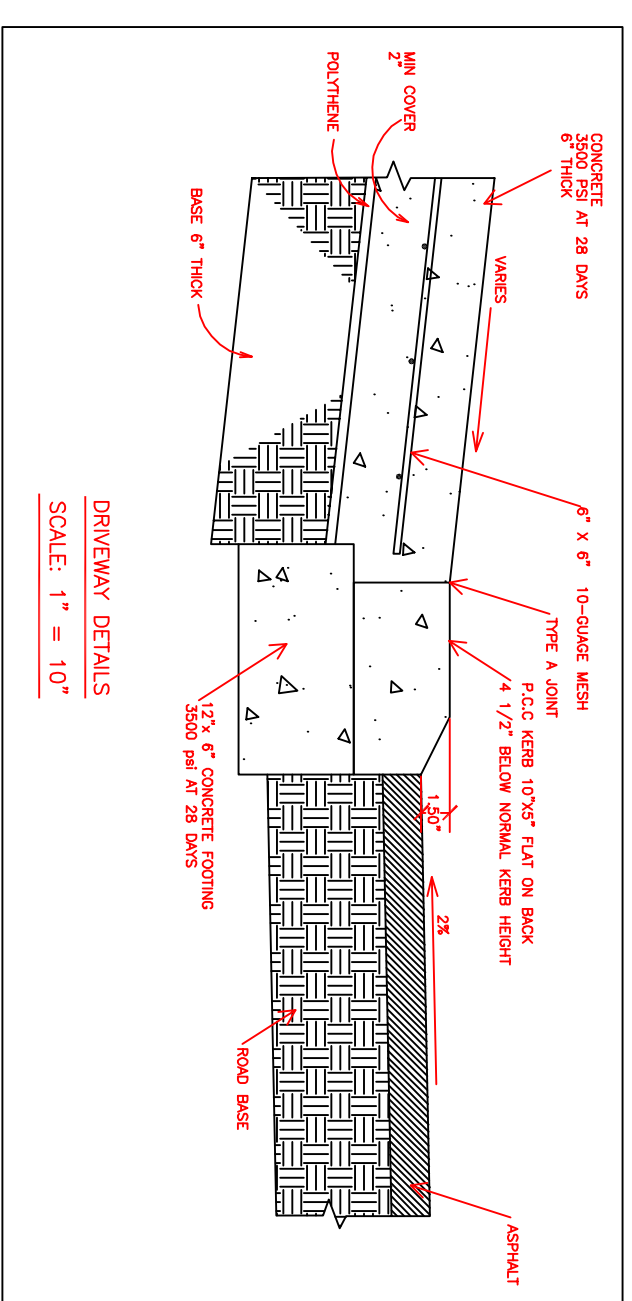

DRIVEWAY DETAILS
SCALE : 1" = 10"

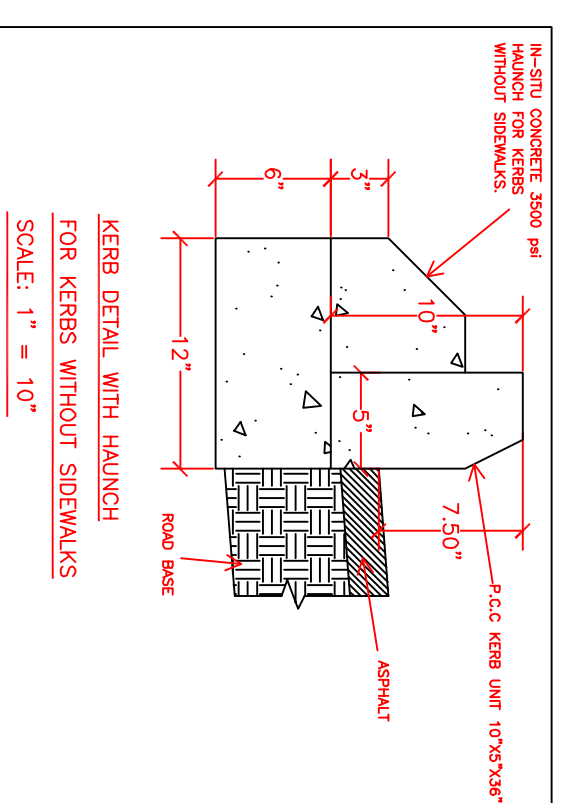

KERB DETAIL WITH HAUNCH FOR KERBS WITHOUT SIDEWALKS
SCALE : 1" = 10"

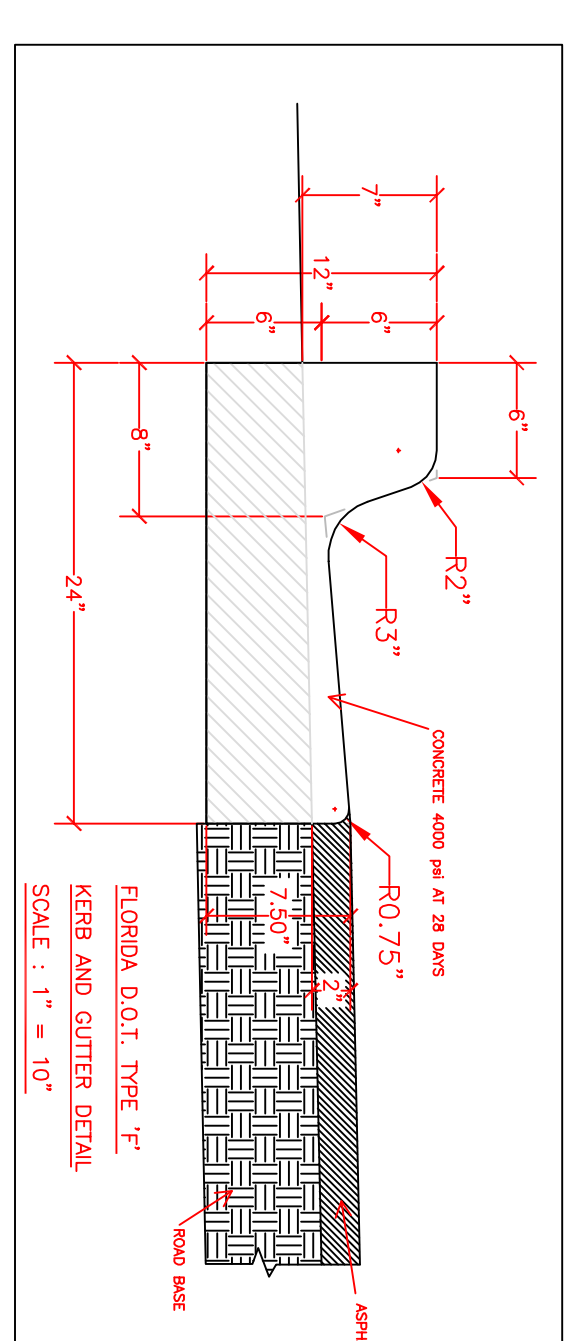
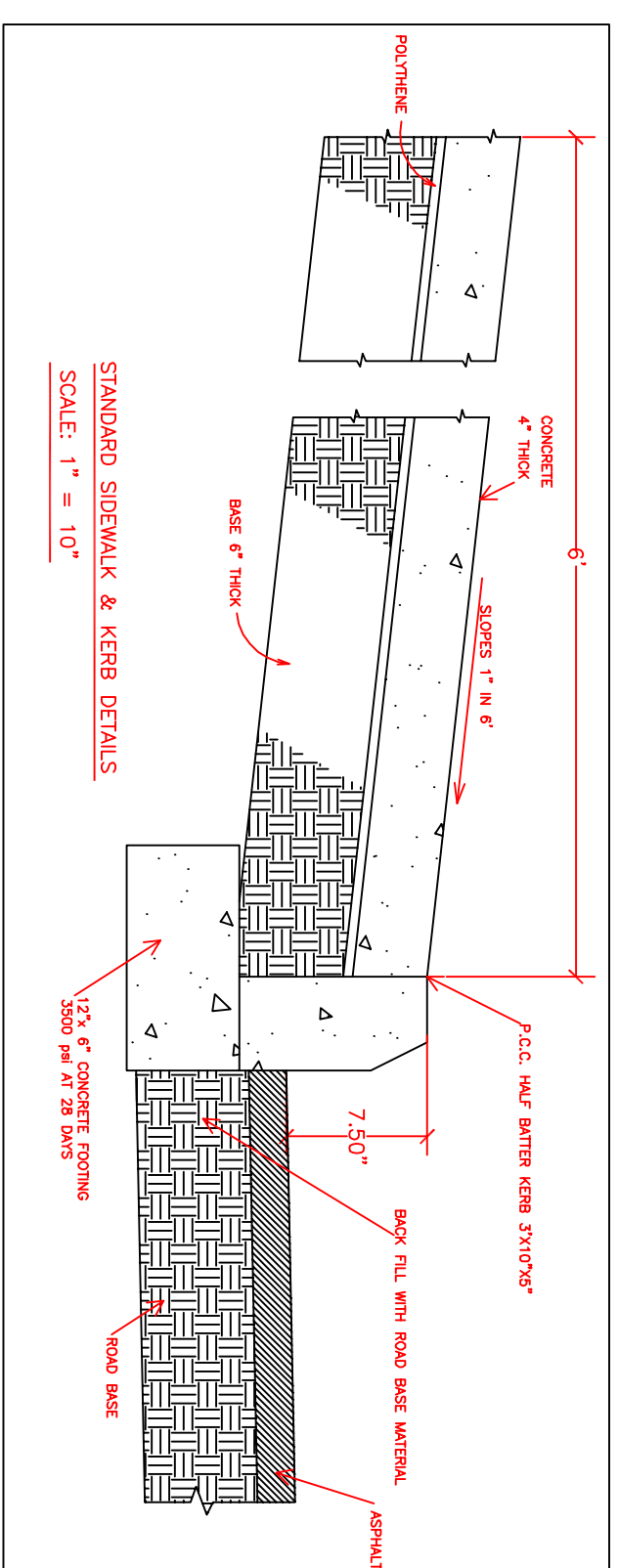
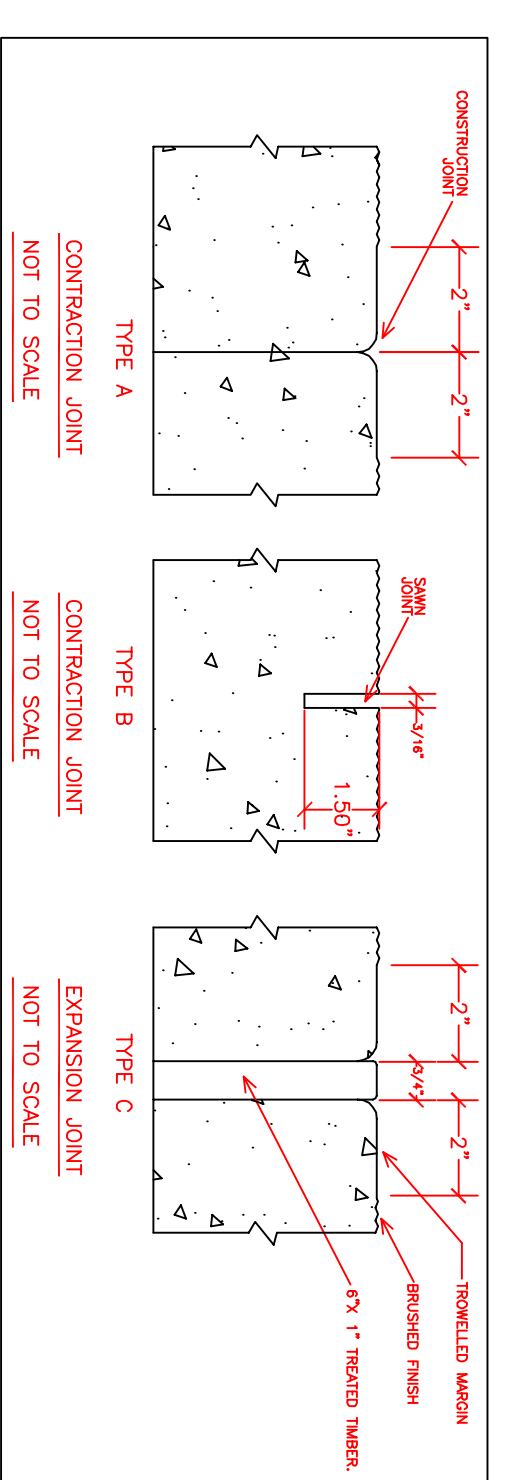

FLORIDA DOT TYPE F KERB AND GUTTER DETAIL
SCALE : 1" = 10"

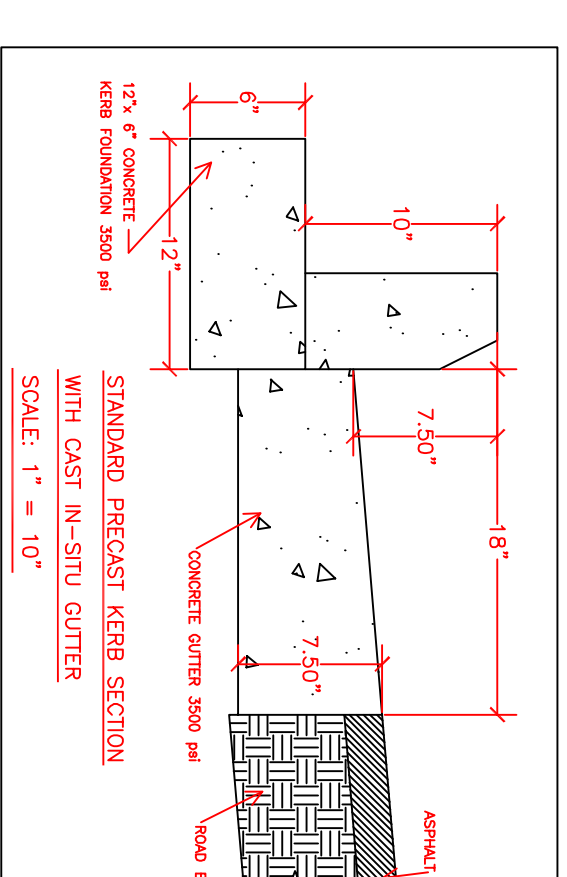

STANDARD PRECAST KERB SECTION WITH CAST IN-SITU GUTTER
SCALE : 1" = 10"

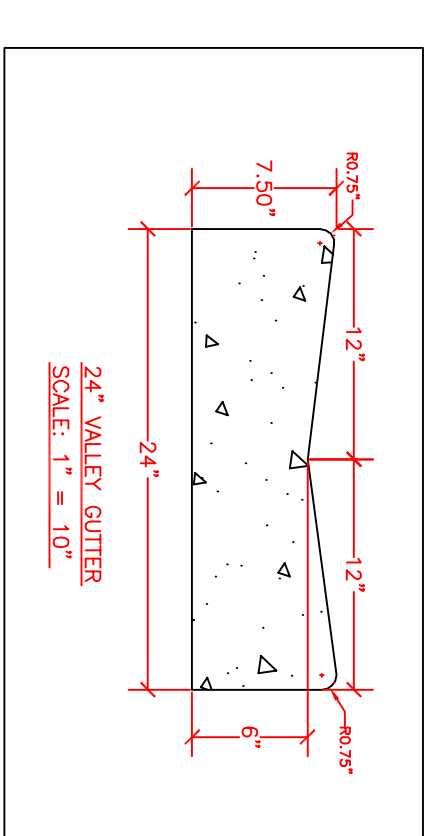

24\"/>

Project ref.	CRB/ROB/SPEC./SPRC/OTHER SPEC.	Design	P. Parchment	No.	Revisions	Date	By
Scale	Horiz. AS SHOWN Vert. N/A	Drawn	D. Myles	#1	Slip Form Type 'F' Added	Oct. 04 2006	
Checked	P. Ogden						
Date:	14/10/99						
Dwg. No.	1						

From sta.	
To sta.	
Sheet	1 of